

61576

PCB Piezotronics Inc. claims proprietary rights in the information disclosed hereon. Neither it nor any reproduction thereof will be disclosed to others without the written consent of PCB Piezotronics Inc.

REVISIONS		
REV	DESCRIPTION	DIN
NR	RELEASED TO DRAFTING	44213

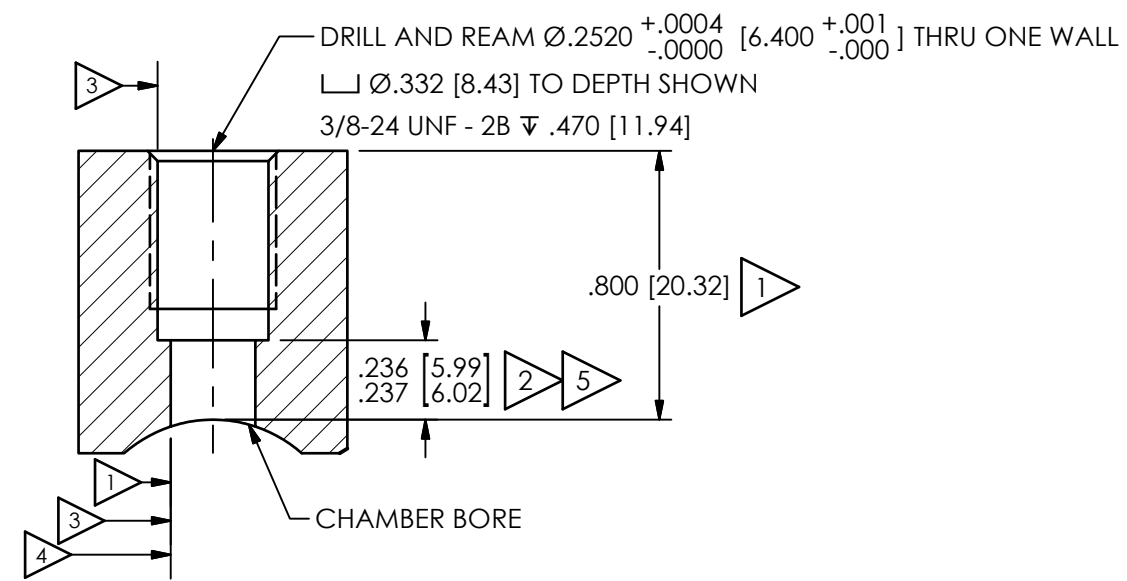

**SHOTSHELL FLUSH MOUNTING**

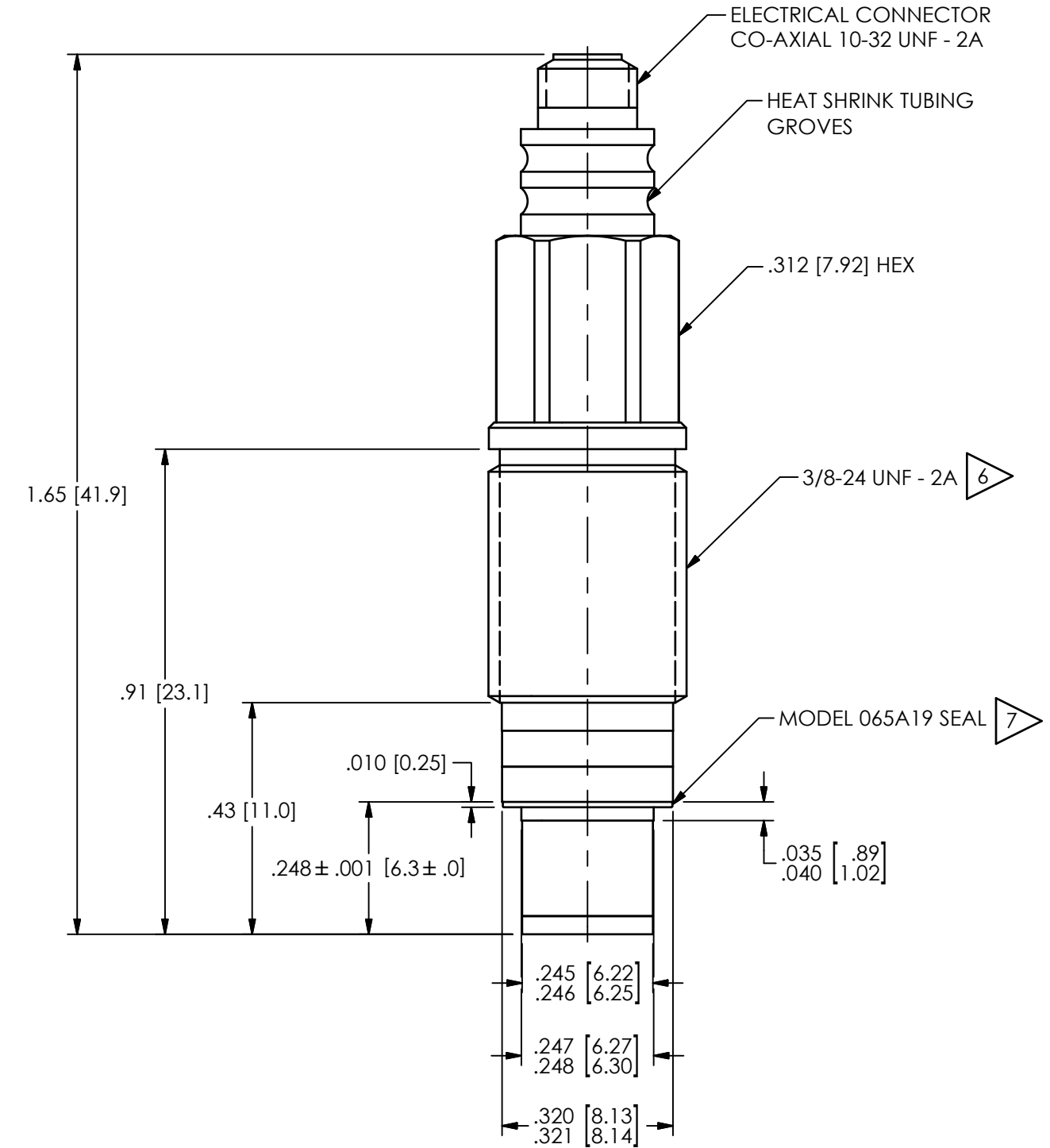

- 7 USE APPROPRIATE 065A19 SPACER TO MOUNT SENSOR TANGENTIALLY FLUSH OR SLIGHTLY RECESSED TO BORE OF BARREL
- 6 RECOMMENDED MOUNTING TORQUE 20-24 FT LBS. [27-33 NEWTON METERS]
- 5 HOLD THIS DIMENSION TO OBTAIN FLUSH MOUNT
- 4  $\varnothing$  OF .2520 [6.400] HOLE MUST INTERSECT  $\varnothing$  OF CHAMBER BORE WITHIN .001 [.03] TIR.
- 3 THESE DIAMETERS MUST BE CONCENTRIC TO WITHIN .001 [.03] TIR.
- 2 SEAL SURFACE MUST BE FLAT AND FREE OF TOOL MARKS WITH A MIN  $\sqrt[63]{(1.6)}$
- 1 DIMENSIONS SHOWN ARE FOR .800 [20.32] THICK WALL.  $\llcorner$  FOR THICKER WALLS

UNLESS OTHERWISE SPECIFIED TOLERANCES ARE:		DRAWN		CHECKED		ENGINEER	
DIMENSIONS IN INCHES	DIMENSIONS IN MILLIMETERS [IN BRACKETS]	BB	6/15/15	ECB	6/15/15	MJK	6/15/15
DECIMALS XX ±.01 XXX ±.005	DECIMALS X ±.03 XX ±.013	TITLE					
ANGLES ± 2 DEGREES	ANGLES ± 2 DEGREES	INSTALLATION DRAWING MODEL 118A07 PRESSURE SENSOR					
FILLETS AND RADII .003 - .005	FILLETS AND RADII 0.07 - 0.13	CODE IDENT. NO. 52681		DWG. NO. 61576		SCALE: 4X SHEET 1 OF 1	

**PCB PIEZOTRONICS**  
 3425 WALDEN AVE. DEPEW, NY 14043  
 (716) 684-0001 E-MAIL: sales@pcb.com